

K60 Drilling Rig

RigKits offers the customer the ability to assemble their own drilling equipment. The kit comprises of all fabricated parts, hydraulic valves, pumps, and cylinders to build the basic **K60** drilling rig. At just five foot wide (1.5m) the unit can get into most back yards. It has an onboard rod rack that can hold 320 foot of 10' rods and is capable of drilling over 500' deep. The K60 makes loop installation as fast and efficient as possible. A total weight of around 10,100lbs (4,600kg) keeps transportation costs down. It is capable of drilling with augers, casings and DTH hammers making it possible to drill through all ground conditions. The K60 was designed specially for the limited access residential retrofit installations of geothermal loops with low engine exhaust, sound emissions and ground pressure. With 9,580lbs.ft (13k Nm) of torque and 19,800lbs of pullback the K60 makes getting out of difficult situations easy.

Standard Equipment:

- 2 Speed high torque rotation head with 2 3/8" (60mm) through bore for direct flushing.
- Mast side to side movement $\pm 18^\circ$.
- Mast fore and aft movement $+3^\circ$ to -90° .
- Standard mast height 17' 10" (5.45m).
- Breakout Clams, 9" bore (229mm) with hydraulic wrench cylinder clamp option.
- 20,000lbs (9070kg) Extraction Force.
- Yanmar Diesel Engine, 83hp (62kW).
- Rod Rack, holds 320' of 10' drill rods.
- Head Slide, 24" horizontal stroke.
- 5' wide crawler tracks for limited access sites.
- Top Winch Mast Extension, 2000lbs line pull.
- 4 Hydraulic Stabilizer Jacks
- Swing-out operator control arm, for safe, easy view when drilling.

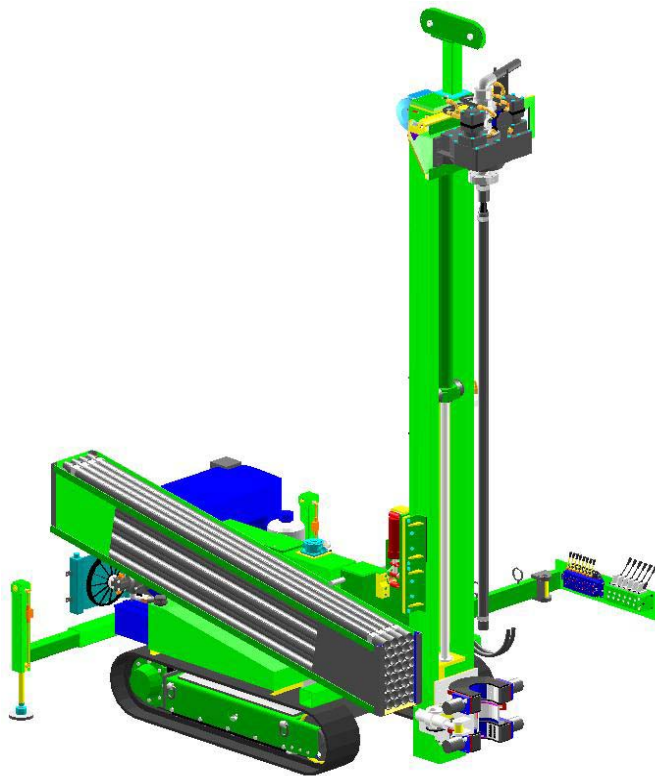

Specifications:

Height when drilling.*	5.4m	17'10"
Height in transport position	1.5m	5'
Width	1.5m	5'
Length in drill position	3m	9'8"
Weight.*	4,626kg	10,200lbs
Feed Stroke	3.8m	12'5"
Pull Back	9,070kg	20,000lbs
Maximum Torque	13 kNm	9,580 lbs.ft
Engine	62kW	83hp

*Dependant on options.

RigKits reserves the right to change specifications at any time without incurring obligation.

RigKits LLC

NC, USA

647-345-0609

info@rigkits.com

www.rigkits.com



Distributed By: